

Give Your Roof A Boost.

It's easy to achieve the beauty of an authentic mortar-boosed clay roof with our Boosted Cap tiles. These individual Boosted Cap pieces are available in all of our colors, including our new Artisan Series. Simply select a Boosted Cap color to complement your Capistrano tile. To customize your look, contact your Eagle Representative or Design Center for help combining colors.

Choose a Boosted Cap accessory piece to go with your base Capistrano field tile. Then decide how much "Boost" to use and how you would like your mortar to look. Some prefer a neat treatment, while others like an authentic look. No matter your choice, your new Boosted Eagle roof will be beautiful for years to come.

% used on roof	Aprox. installed weight field tile per 100 sq ft
10% Application	968
20% Application	1056
30% Application	1144

Each Boosted Capistrano cap weighs approx 4.8 lbs.

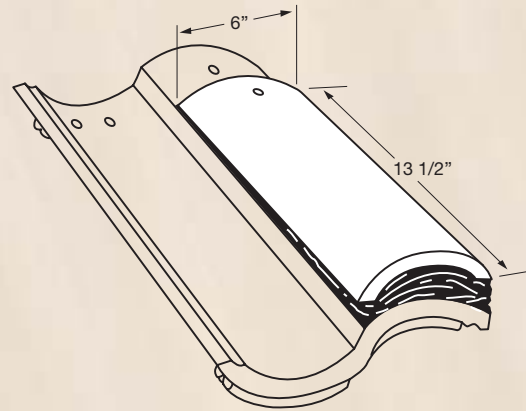

Boosting The Eave



Placing The Mortar*



Close-Up of Boosted Eave



Boosted Wind Clips Included (Bronze & Stainless Steel)

**Capistrano & Boosted Capistrano
3520 & 9520 Weathered Terracotta Flashed
30% Boosted Application**

Boosted Capistrano



10% Boosted



20% Boosted



30% Boosted